

**M/s. PARASAKTI CEMENT INDUSTRIES LTD.,**  
**Jettipalem (Village & Post), Rentachintala (Mandal)**  
**Guntur (Dist.) – A.P.**

**ENVIRONMENTAL STATEMENT (AUDIT)**  
**FOR THE FINANCIAL YEAR 2018-2019**



**UNIVERSAL ENVIRO ASSOCIATES**  
**104 & 105 Libra Enclave, RTC 'X' Roads,**  
**Musheerabad, Hyderabad – 500 020.**  
**Ph: 27633361.**

## **ACKNOWLEDGEMENT**

**M/s. UNIVERSAL ENVIRO ASSOCIATES** express since debt of gratitude to **M/s. PARASAKTI LIMESTONE MINES (M/s. Parasakti Cement Industries Limited)** for the opportunity given by assigning the preparation of Environmental Statement (Audit) for their Mines located near Jettipalem (V) Rentachintala (M), Guntur (Dist) of Andhra Pradesh. The Environmental Statement (Audit) is prepared for the financial year from April, 2018 to March, 2019. Special mention needs to be made of executives of M/s. Parasakti Lime Stone Mines (M/s. Parasakti Cement Industries Limited) for their cooperation and assistance during the preparation of Environmental Statement. We also wish to acknowledge our gratitude to all of them who helped during the data collection and report preparation.

## **CONTENTS**

|  |      |
|--|------|
| Acknowledgement  | 2    |
| Contents   | 3    |
| List of Tables   | 4    |
| List of Figures  | 4    |
| FORM – V   | 5    |
| 1. INTRODUCTION  | 12   |
| 2. OBJECTIVE OF THE STUDY                                | 12   |
| 3. BENEFITS OF ENVIRONMENTAL AUDIT                       | 13   |
| 4. LOCATION  | 14   |
| 5. PROCESS DESCRIPTION                                   | 16   |
| 6. WATER REQUIREMENT                                     | 23   |
| 7. POLLUTION CONTROL IN THE PLANT                        | 23   |
| 7.1 Waste water sources and Monitoring                   | 23   |
| 7.2 Air Pollution Control                                | 23   |
| 7.2.1 Stack Emission                                     | 23   |
| 7.2.2. Ambient Air Quality                               | 26   |
| 7.2.3. Noise Pollution                                   | 27   |
| 8. GREENBELT DEVELOPMENT                                 | 28   |
| 9. HOUSE KEEPING   | 29   |
| <b>APPENDIX</b>  |      |
| A. National Ambient Air Quality Standards                | i    |
| B. Standard for Stack Emissions                          | iii  |
| C. Ambient Air Quality Standards in Respect Noise        | iii  |
| D. General Standards for Discharge of Effluents          | iv   |
| E. Test Characteristics for Drinking Water IS 10500:1991 | vi   |
| F. Plant Species for Green Belt Development              | viii |

**LIST OF TABLES**

|   |       |
|---|-------|
| 7.1. Air pollution control equipments (Unit – I & II) | 24-25 |
| 7.2. Average Values of Ambient Air Quality Data       | 26    |
| 7.2.3. Average values of Ambient Noise Level          | 27    |

**LIST OF FIGURES**

|   |    |
|---|----|
| Fig. 1. Location Map of M/s. PARASAKTI CEMENT INDUSTRIES LTD. | 15 |
| Fig. 2. Process flow Diagram of Cement Manufacturing .        | 22 |

**FORM - V  
(See rule 14)**

**ENVIRONMENTAL STATEMENT REPORT FOR THE FINANCIAL  
YEAR ENDING THE 31<sup>ST</sup> MARCH 2019**

**PART – A**

|   |   |   |
|---|---|---|
| 1 | Name and address of the owner/<br>occupier of the industry operation<br>or process. | <b>M/s. Parasakti Cement Industries Ltd.,</b><br>Plot No. 8-3-214/21,<br>Srinivasa Nagar Colony (West),<br>Hyderabad – 500 038.<br><br><b>Factory:</b><br>Jettipalem, Rentachintala Mandal,<br>Guntur District, Andhra Pradesh.<br>Phone: 9866700013/14 |
| 2 | Industry Category<br>Primary: (STC Code)<br>Secondary: (STC Code)                   | Primary   |
| 3 | Date of last environmental audit<br>Report submitted                                | September, 2018   |
| 4 | Production Capacity (units)   | Clinker Production – 1.20 MTPA<br>Cement Production – 1.26 MTPA   |
| 5 | Year of establishment   | June - 2005   |

**PART – B**

| <b>Water and Raw Material Consumption</b> |        |     |
|---|--------|-----|
| <b>a) Water consumption</b>               | 196.42 | KLD |
| 1. Process consumption & Dust suppression | 102.34 | KLD |
| 2. Domestic                               | 94.08  | KLD |

| Name of Products | Water consumption per unit of product<br>(KL/MT)     |   |
|------------------|--|---|
|                  | During the previous<br>financial year<br>(2017-2018) | During the current<br>financial year<br>(2018-2019) |
| Cement           | 0.096  | 0.062   |

| <b>ii) Raw material &amp; chemicals consumption</b> |                 |      |   |  |
|---|-----------------|------|---|--|
| Name of raw materials                               | Name of product | Unit | Consumption of raw material per MT<br>of output based on MT of Cement |  |
|   |                 |      | During the<br>previous<br>financial year<br>(2017-2018)               | During the<br>current<br>financial year<br>(2018-2019) |
| Lime Stone  | Clinker         | MT   | 1.410   | 1.405  |
| Laterite  |                 | MT   | 0.050   | 0.055  |
| Iron Ore  |                 | MT   | 0.030   | 0.028  |
| Dolomite  |                 | MT   | 0.010   | 0.017  |
| Slag  |                 | MT   | Nil   | 0.0019   |
| Coal  |                 | MT   | 0.140   | 0.151  |
| Gypsum (OPC)  | Cement          | MT   | 0.050   | 0.051  |
| Fly Ash (PPC)                                       |                 | MT   | 0.330   | 0.324  |

**PART - C**  
**POLLUTION GENERATED**

(Parameter as specified in the consent issued)

| Pollutants                                 |                        | Quantity of Pollutants Discharged (kg/day) 2018-2019 | Concentrations Of Pollutants in Discharges (mg/L) 2018-2019 | Percentage of variation from prescribed standards with reasons |
|--|------------------------|--|---|--|
| <b>a) Treated Waste Water</b>              |                        |  |   |  |
| 1  | Total Dissolved Solids | 65.51  | 507.83  | 75.81% less  |
| 2  | Suspended solids       | 6.69   | 44.18   | 55.82% less  |
| 3  | C.O.D.                 | 3.34   | 25.94   | 89.64% less  |
| 4  | B.O.D.                 | 0.91   | 7.10  | 76.33% less  |
| 5  | Oil & Grease           | 0.15   | 1.20  | 88.00% less  |
| <b>Average Effluent Quantity 129.0 KLD</b> |                        |  |   |  |

| <b>b) Air.</b>       |            |  |   |  |
|----------------------|------------|--|---|--|
| Stack Attached to    | Pollutants | Quantity of Pollutants Discharged (kg/day) 2018-2019 | Concentrations Of Pollutants in Discharges (mg/L) 2018-2019 | Percentage of variation from prescribed standards with reasons |
| Kiln – I             | PM         | 79.43  | 21.82   | 29.33% less  |
| Cooler - I           | PM         | 67.58  | 21.38   | 28.73% less  |
| Coal Mill – I        | PM         | 9.78   | 18.33   | 38.90% less  |
| Cement Mill –I       | PM         | 14.36  | 17.96   | 40.13% less  |
| Cement Mill-Vent-I   | PM         | 15.73  | 19.30   | 35.66% less  |
| Kiln – II            | PM         | 122.18   | 20.24   | 32.53% less  |
| Cooler – II          | PM         | 75.08  | 20.51   | 31.63% less  |
| Coal Mill – II       | PM         | 30.27  | 21.72   | 27.60% less  |
| Cement Mill – II     | PM         | 16.77  | 22.08   | 26.40% less  |
| Cement Mill-Vent- II | PM         | 31.64  | 21.45   | 28.46% less  |
| Crusher              | PM         | 4.63   | 21.52   | 28.26% less  |
| Raw Mill Vent-II     | PM         | 25.40  | 20.65   | 31.16% less  |

**PART - D  
HAZARDOUS WASTE**

(As specified under Hazardous wastes/Management and handling Rules, 2003)

| Hazardous wastes                        | Total Quantity per year                        |   |
|---|--|---|
|   | During the previous financial year (2017-2018) | During the current financial year (2018-2019) |
| <b>From Process</b>                     |  |   |
| Batteries scrap- used batteries         | 0.229 Ton                                      | 1.034 Ton                                     |
| Used Grinding Media                     | 45.00 Ton                                      | Nil   |
| Waste Lube Oil                          | Nil  | 1.05KL  |
| Waste Grease                            | 1.44 MT  | 7.098 MT                                      |
| <b>From Pollution Control facility</b>  |  |   |
| <b>Quantity recycled or Re-utilized</b> |  |   |

**Note: Waste Oil and Grease generated from plant.**

**PART – E  
SOLID WASTES**

| Solid Wastes   | Total Quantity                                 |   |
|--|--|---|
|  | During the previous financial year (2017-2018) | During the current financial year (2018-2019) |
| <b>From Process</b>                                    |  |   |
|  | NIL  | NIL   |
| <b>From Pollution Control Facilities</b>               |  |   |
|  | NIL  | NIL   |
| <b>Quantity recycled or reutilized within the unit</b> |  |   |
|  | NIL  | NIL   |

## **PART - F**

**Please specify the characteristics (in terms of concentration and quantum) of Hazardous as well as solid wastes and indicates disposal particles adopted for both these categories of wastes.**

About 1.034 MT of Used batteries scrap, 7.098 MT waste grease, 1.05KL Lube oil, 2018 March Generated 8.0 MT High-Crome Grinding Media Scrap of have been generated from the plant. 1.034 MT of Used batteries scrap is sold to Aman industries Guntur. 8.0 MT High-Crome Grinding Media Scrap is sold to M/s. Marto pearl Alloys Pvt Ltd Hyd. 7.098 MT waste grease M/S Sri Padmavathi Energy solutions India (p) Ltd Hyd. an agencies authorized by APPCB 1.05kL MT Lube oil is used internally for self consumption.

No Solid waste is generated from the Plant as it is a dry process. The intermediate products, raw material and finished product collected in various pollution control systems is being recycled in to the process.

## **PART – G**

**Impact of the pollution control measures on conservation of natural resources and consequently on the cost of production.**

-Nil-

## **PART - H**

### **Additional investment proposal for environmental protection including abatement of pollution.**

1. An amount of Rs.2, 52,960/- is spend on regular monitoring.
2. Total investment on the greenbelt development for the year 2018-19 is Rs.21, 28,016/-.
3. Total investment on the maintenance of the pollution control equipments for the year 2018-19 is Rs. 76,99,285/-
4. Total investment on STP, Vacuum cleaner, Drinking welfare & road sweeping maintenance for the year 2018-19 is Rs.12,62,378/-
5. APPCB Analysis charges & Water Cess Rs.69, 831/-.

## **PART - I**

### **Any other particulars in respect of environment protection and abatement of pollution.**

- Parasakti Cement Industries Ltd., (PCIL) is conducting regular meeting for reviewing and taking up various improvements in the quality of the Safety and Environment.
- PCIL is conducting regular environmental monitoring to comply the conditions of APPCB/ MOEF.
- PCIL incurred an amount of Rs.3,81,54,247/- towards the power consumption on pollution control equipment.

## **1. INTRODUCTION**

M/s. Parasakti Cement Industries Limited has setup Cement manufacturing unit at Jettipalem Village, Rentachintala Mandal, Guntur District of A.P. The Plant is established in the year of 2005. M/s. Parasakti Cement Industries Limited is manufacturing Ordinary Portland Cement (OPC) 53 grade, OPC 43 grade and PPC with a production capacity is 1.20 MT/A (Clinker) & 1.26 MT/A (Cement).

## **2. OBJECTIVE OF THE STUDY:**

The objective of the present study is to review the performance of pollution control systems installed by the industry so as to identify efficient pollution prevention and control systems, which could be beneficial to both environment and its components. And also **Inserted by rule 2 of the Environment (Protection) second Amendment & Rules, 1992 vide G.S.R. 329 (E), dated: 13-3-1992.** Every person carrying on an Industry, operation or process requiring consent under section 25 of the water (prevention and control of pollution) Act 1974 (6 of 1974) or under section 21 of the Air (Prevention and Control of Pollution), Act 1981 (14 of 1981) or both or authorization under the Hazardous wastes (Management and Handling) Rules, 1989 issued under the Environmental (Protection) Act 1986 (29 of 1986) shall submit an environmental audit report for the financial year ending 31<sup>st</sup> March in Form – V to the concerned state pollution control board on or before the 30<sup>th</sup> day of September every year beginning 1993.

### **3. BENEFITS OF ENVIRONMENTAL AUDIT**

Environmental audit creates awareness in the conservation of natural resources and helps to improve production safety and health. The benefits of audits are:

1. It helps in reduction of raw material consumption by way of waste minimization and adoption of recovery of waste and recycles the same.
2. Determined the performance of process systems and helps to improve the systems.
3. Efficiency of pollution control systems can be calculated.
4. This gives the awareness of environmental organization in the industry.
5. Data available will help the management for use in the plant modification and adopting pollution control for different types of technology.
6. It helps to identify pollution creating systems and exposure to it by the employees for taking remedial measures.
7. The management will be assisted in complying with local, regional and national laws regulations by adopting standards.
8. It helps to identify hazardous wastes, handling measures taken and exposure to litigation can be reduced.
9. To determine the impact on the surrounding environment due the disposal of its pollutants and identify suitable preventive measures.
10. Energy saving systems can be adopted by considering fuel consumption data.

M/s. Parasakti Cement Industries Limited has entrusted the task of preparation of Environmental Statement (Audit) to M/s. UNIVERSAL ENVIRO ASSOCIATES (UEA), Hyderabad. An in-depth study was conducted by UEA, to review the process efficiency, waste water generated and the present treatment systems, emissions generated and air pollution control equipment provided mode of solid waste collection and disposal and the other associated problems leading to the pollution and impact on environment.

#### **4. LOCATION**

The M/s. Parasakti Cement Industries Limited is situated in Jettipalm Village, Rentachintala Mandal, Guntur district of Andhra Pradesh. The Plant is situated 30 km away from Macharla by the side of Macharla – Piduguralla road. **The project site falls under the Latitude 14<sup>0</sup>35' - 14<sup>0</sup>45' of North and Longitude of 78<sup>0</sup>30' - 78<sup>0</sup>35' East.** The project area is rocky in nature. The site comes under arid zone. **The Location map and Plant layout are show in Fig. 1.**

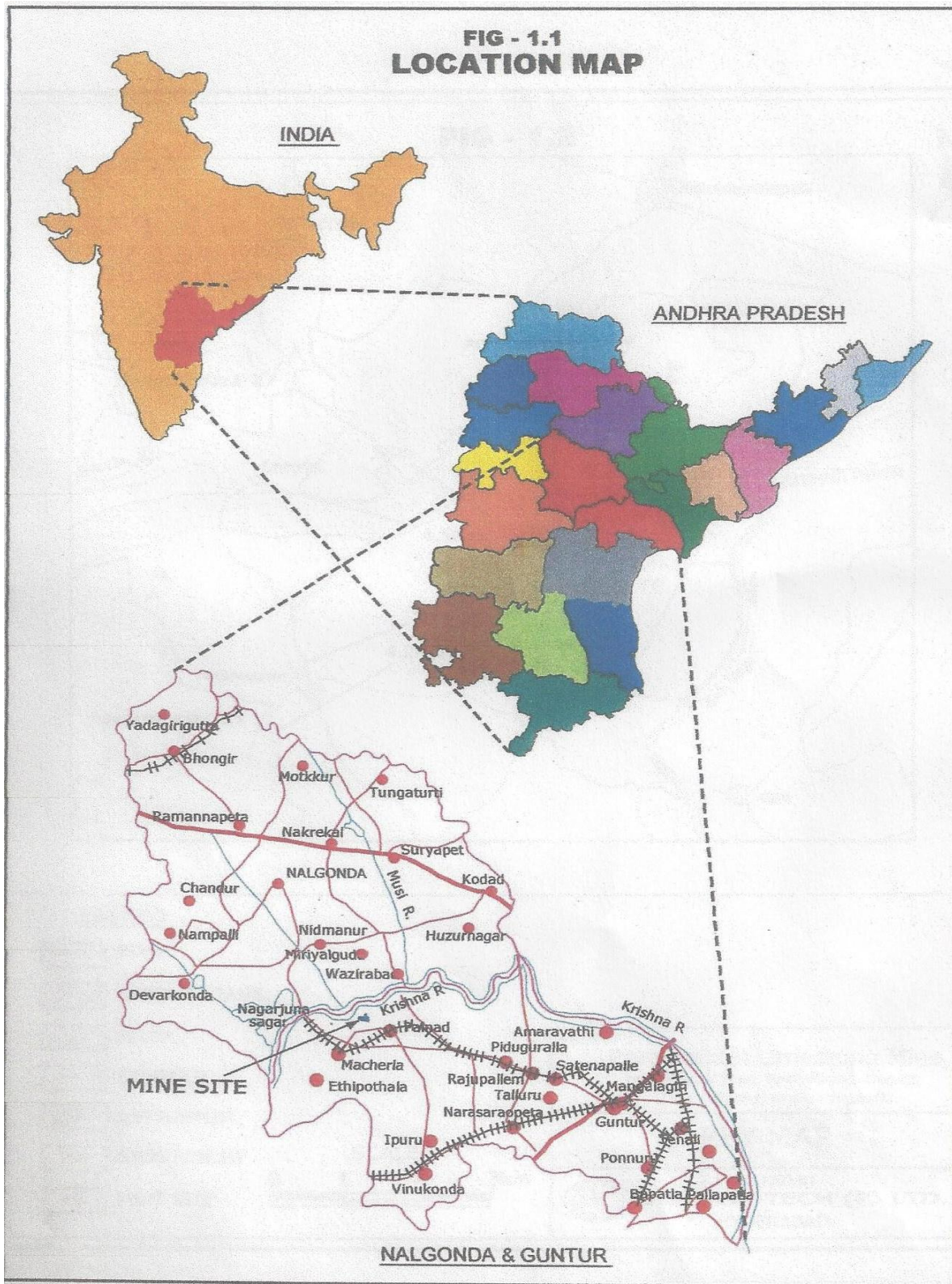

## **5. PROCESS DESCRIPTION:**

The limestone is drilled, blasted and then loaded by hydraulic excavators into dumpers, which transports the limestone boulders to the crusher. After crushing it sent to stockpile.

### **The stages of cement manufacture at PCIL are as follows:**

- |    |                                  |   |         |
|----|----------------------------------|---|---------|
| 1. | Mining & Crushing of limestone   | - | Stage 1 |
| 2. | Raw meal grinding                | - | Stage 2 |
| 3. | Coal grinding                    | - | Stage 3 |
| 4. | Clinker Production (Pry process) | - | Stage 4 |
| 5. | Cement grinding                  | - | Stage 5 |
| 6. | Packing of Cement                | - | Stage 6 |

### **1. Mining and Crushing of limestone**

Lime for Parasakti Cement is mined at our captive limestone mine, Parasakti Limestone Mines and crushed in the compound impact crusher. The crushed limestone is stocked in the limestone stock pile. The stock pile bays are demarcated for high grade and low grade limestone. Depending on the analysis the crushed limestone is stocked in the respective bays.

### **2. Raw meal Grinding**

Raw meal is prepared by grinding limestone and additives in suitable proportions in Raw Mill. Raw Mill feed system consists of 4 hoppers. For maintaining uniform particle size in the ground raw meal, the raw mill system is equipped with a High efficiency separator. In the 4 hoppers, one hopper is meant for High grade limestone, second hopper for Low grade limestone, the third hopper for Iron ore and the fourth for Laterite. All the four hoppers are

equipped with weigh feeders. Proportioned and weighed quantities of raw materials are fed to the Raw mill to meet the quality requirement.

Tertiary crusher is installed after weigh feeders, for further reduction of limestone size before entering the raw mill.

Raw mill is a tube mill filled with required quantity of grinding media charged inside. Raw mill consists of a drying chamber for drying of raw materials and two grinding chambers. The ground material from 1<sup>st</sup> and 2<sup>nd</sup> chambers is drawn out of the mill with air sucked through raw mill fan. The ground material is discharged into an air side and is carried to high efficiency separator through air slides and bucket elevator. In the separator, the ground material is separated to finer and coarse fraction. Finer fraction, called raw meal is transported to Raw meal silo, a continuous flow silo by Belt Bucket Elevator or Vertical Pneumatic Pump.

The fine dust in the air is collected in a Cyclone and the air is sent to Bag House. The collected dust is mixed with raw mill product when raw mill is running and to a separate dust silo when raw mill is stopped. The dust in silo will be added to the raw mill product when the mill is running.

### **3. Fine Coal Grinding**

Incoming raw coal is unloaded into a hopper. Truck unloading system is installed in the plant for coal unloading. The coal from the hopper is conveyed to the raw coal crusher. The crushed coal is stocked in the coal stock pile in different bays as per the grade of coal. Fine coal is prepared by grinding crushed coal. The coal mill system consists of a two chambered air swept tube mill (one drying chamber and one grinding chamber), grit separator and a

bag house. The coal from the raw coal hopper is fed to the mill through rotary table feeder. The dried coal from drying chamber then passes to grinding chamber filled with grinding media. Hot air from the Kiln cooler is utilized for the drying of coal. The powdered coal is swept to grit separator, by air because of the induced draft created by coal mill bag filter fan, where fines and coarse are separated. Coarse material is returned back to mill for further grinding and fines are swept to bag house where fines are collected and stocked in fine coal bins.

#### **4. Production of Clinker**

Clinker preparation is subdivided into 4 stages.

- Raw meal extraction,
- Preheating & Precalcination
- Burning (Clinkerisation)
- Cooling
- Recycling of Dust

#### **Raw meal Extraction:**

The material stored in continuous flow silo, which is storage cum blending silo. The inverted central cone silo creates a good blending effect on the raw meal. The silo is equipped with multiple gates that are operated in auto/manual mode. The material is extracted in a cycle of multiple gates opening at a time for fixed period. This cycle feeds homogenized raw meal to the preheater system. This extracted raw meal is called Kiln Feed.

The extracted raw meal is discharged in to kiln feed storage bin using air slides. From the storage bin, weighed quantity of kiln feed using solid flow meter is transported to preheater system by Belt Bucket Elevator or V.P. Pump.

**Preheating & Pre-Calcinations:**

The kiln feed is preheated and partly calcined by hot kiln exit gases in a tower of heat exchange cyclones called Preheater. The heat exchange between gas and the material takes place in the cyclones, in suspension of material and gas.

The preheater at PCIL is a 5 stage preheater equipped with precalcinator, called RSP (Reinforced Suspension Preheater). The material from the 4<sup>th</sup> stage of preheater is fed into the pre-calcinator called Swiri calciner. 60% of the fuel required for clinkerisation is fed into this calciner system along with hot recouped air from cooler called Tertiary air. The material from the precalciner goes to 1<sup>st</sup> stage of the preheater before entering the kiln. By the time it enters the kiln, the kiln feed attains about 80-95% of degree of calcinations.

**Burning (Clinkersation):**

The final clinkerisation of the kiln feed takes place in the rotary kiln. 40% of fuel required for clinkerisation is fed into the kiln for burning. The precalcined kiln feed entered from preheater is further heated in the rotary kiln to about 1350 - 1450<sup>0</sup>C at which clinker form is formed.

**Cooling:**

The clinker produced in the kiln is cooled from 1100 - 1400<sup>0</sup>C to 120-150<sup>0</sup>C in the grate cooler by air quenching. The cooler is fitted with slotted grate plates. As the clinker moves on the grates towards the discharge end of the cooler, air is blowed from the bottom of the

plates and cools the clinker. The hot air generated, is recouped and utilized for clinker burning as secondary air for the kiln and tertiary air for precalcinator.

**Recycling of Dust:**

The dust laden exhaust gases from the preheater are passed Reverse Air Bag House (RABH), where the fine dust is collected and clean gases are released into the atmosphere. The dust collected is transported back to raw meal silo along with raw mill product. When the raw mill is not running this dust is collected in an intermediary dust silo and then mixed with the raw mill product, when raw mill is running.

**5. Cement Grinding:**

Cement is ground by grinding clinker, fly ash and gypsum in suitable proportions. Cement mill at PCIL are closed circuit ball mills. Each Cement mill is having of 3 hoppers (one for clinker, second for Gypsum and one for spare). For fly ash separate metallic storage silos are installed. Weighed quantity of Fly ash is extracted through solid flow meter from the bottom of the silo and pumped to high efficiency separator.

Weigh feeders are installed to every hopper, and Mills are equipped with high efficiency classifiers for better particle size distribution. Weighed & proportioned quantities of clinker, gypsum are fed into the cement mill from hoppers. The cement mill are two chambered mills. The ground cement and fly ash is fed to the separator by air slide and bucket elevator. In the separator, the ground material and fly ash is separated to finer and coarse fraction. Finer fraction is transported to four compartment silo by Bucket Elevator or Vertical Pneumatic Pump.

## **6. Dispatch of Cement**

PCIL has electronic packers with eight spouts for packing the cement into bags and loading into the trucks.

Cement from the silos is extracted through gates and transported to the Hopper in Packer System. Bags are attached to the nozzle of the rotating electronic packer. Filled in bags are automatically discharged from the packer on to the belt conveyers and loaded in to the trucks.

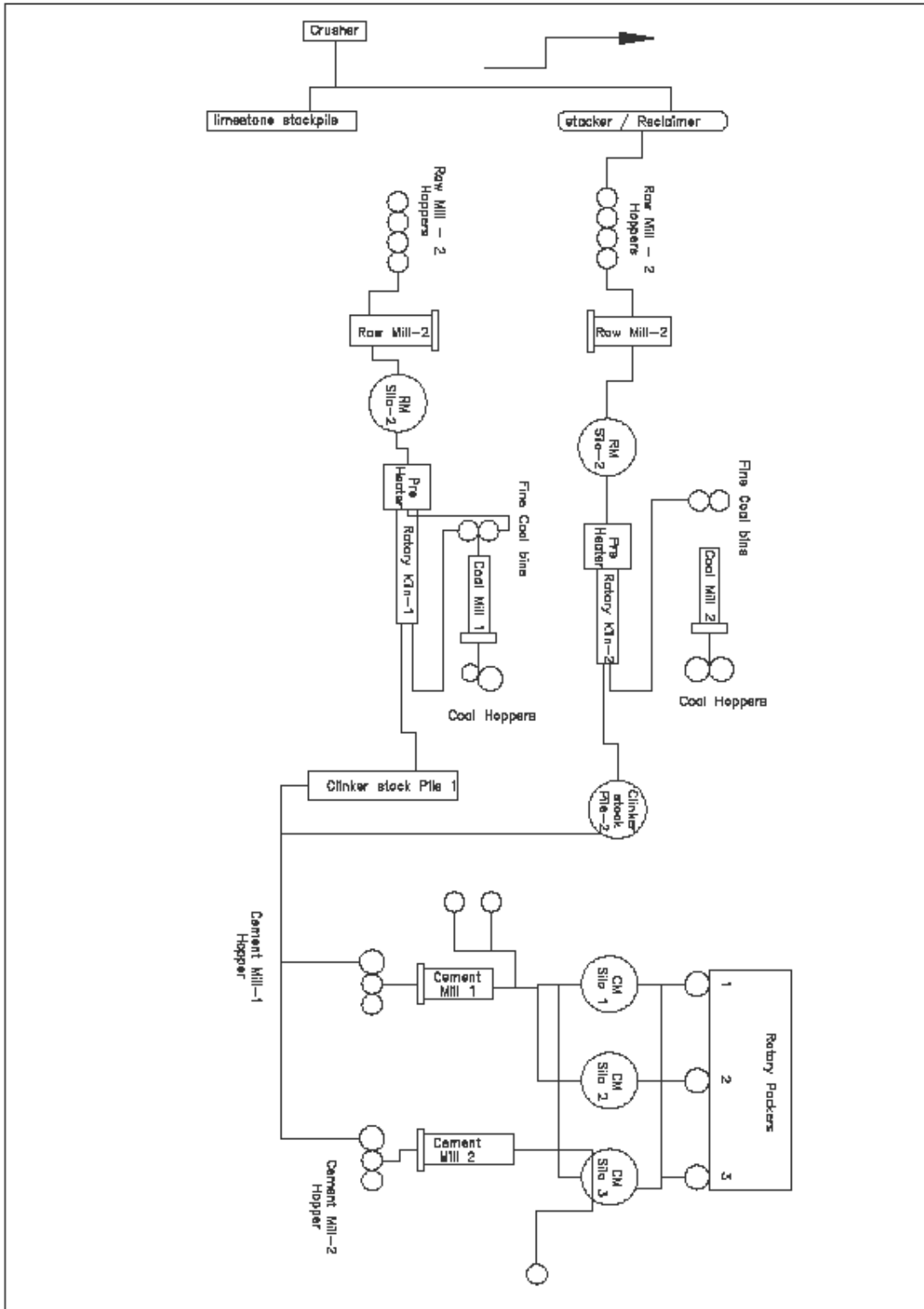

## **6. WATER REQUIREMENT:**

The total consumption is 196.42 m<sup>3</sup>/day and the breakup details are given below:

- |   |   |                            |
|---|---|----------------------------|
| 1. Process consumption & Dust suppression | - | 102.34 m <sup>3</sup> /day |
| 2. Domestic & Gardening                   | - | 94.08 m <sup>3</sup> /day  |

Most of the process and cooling water will be evaporated / consumed. The domestic requirement includes requirements of colony, drinking as well as sanitation. The water requirement is being met from the bore wells.

## **7. POLLUTION CONTROL IN THE PLANT**

The industry has given top priority for pollution prevention and control. Therefore all the sources that release particulate matter are provided with ESP & Bag filters for the control of particulate emissions into atmosphere. Tall stacks are provided as an effective measure for good atmospheric dispersion of the pollutants and air pollution control.

### **7.1 Waste water Sources and Monitoring**

Most of the water consumed for process as well as cooling is consumed/ evaporated. The only source of wastewater is from sanitary facilities of the plant and colony is presently being sent to Sewage treatment plant to treat this wastewater. Discharges from the sewage treatment plant water characteristic meets the discharge standards of APPCB for on-land irrigation.

### **7.2 Air Pollution Control**

#### **7.2.1 Stack Emissions**

The sources of air emissions are from Raw mills & Kiln, Raw mills and kiln, Cooler Stack, Cement Mill –I & II, Coal Mill. Stack emissions monitoring is carried out regularly for the parameters PM. The average values of stack emission data is given in table 7.1. It is noticed

from the collected emissions data that the parameters monitored are within the limits prescribed by A.P. pollution control Board.

**Table 7.1**

| <b>AIR POLLUTION CONTROL EQUIPMENTS</b> |                               |                          |
|---|-------------------------------|--------------------------|
| <b>UNIT – I</b>                         |                               |                          |
| <b>S No.</b>                            | <b>LOCATION</b>               | <b>TYPE OF EQUIPMENT</b> |
| U1-1                                    | RAW MILL & ROTARY KILN        | REVERSE AIR BAG HOUSE    |
| U1-2                                    | COAL MILL                     | BAG HOUSE                |
| U1-3                                    | COOLER                        | ESP                      |
| U1-4                                    | CEMENT MILL                   | ESP                      |
| U1-5                                    | CEMENT MILL VENT              | ESP                      |
| U1-6                                    | LIMESTONE CRUSHER             | BAG HOUSE                |
| U1-7                                    | LIMESTONE HOPPERS TOP         | BAG HOUSE                |
| U1-8                                    | TERTIARY CRUSHER              | BAG FILTER               |
| U1-9                                    | RAW MEAL SILO                 | BAG FILTER               |
| U1-10                                   | RAW MEAL SILO EXTRACTION      | BAG FILTER               |
| U1-11                                   | COAL CRUSHER                  | BAG FILTER               |
| U1-12                                   | COAL TRANSFER POINT           | BAG FILTER               |
| U1-13                                   | COAL FEED CIRCUIT             | BAG FILTER               |
| U1-14                                   | CLINKER DISCHARGE ABOVE DBC   | BAG FILTER               |
| U1-15                                   | CLINKER STOCK PILE SHAFT – I  | BAG FILTER               |
| U1-16                                   | CLINKER STOCK PILE SHAFT – II | BAG FILTER               |
| U1-17                                   | CSP TO TRANSFER POINT         | BAG FILTER               |
| U1-18                                   | CLINKER HOPPER TOP            | BAG FILTER               |
| U1-19                                   | CEMENT SILO                   | BAG FILTER               |
| U1-20                                   | PACKING PLANT                 | BAG FILTER               |
| U1-21                                   | COAL MILL HOPPERS TOP         | BAG FILTER               |
| U1-22                                   | PRE-HEATER TOP                | BAG FILTER               |
| U1-23                                   | FLY ASH SILO TOP              | BAG FILTER               |

| <b>AIR POLLUTION CONTROL EQUIPMENTS</b> |  |                          |
|---|--|--------------------------|
| <b>UNIT – II</b>                        |  |                          |
| <b>S No.</b>                            | <b>LOCATION</b>                            | <b>TYPE OF EQUIPMENT</b> |
| U2-1                                    | RAW MILL VENT                              | BAG FILTER               |
| U2-2                                    | KILN & RAW MILL                            | REVERSE AIR BAG HOUSE    |
| U2-3                                    | COOLER STACK                               | ESP                      |
| U2-4                                    | COAL MILL VENT                             | BAG FILTER               |
| U2-5                                    | CEMENT MILL VENT                           | BAG HOUSE                |
| U2-6                                    | CEMENT MILL STACK                          | ESP                      |
| U2-7                                    | TP-8 (@RMH-II FEEDING)                     | BAG FILTER               |
| U2-8                                    | RM HOPPERS TOP                             | BAG FILTER               |
| U2-9                                    | TERTIARY CRUSHER (RMH BOTTEM)              | BAG FILTER               |
| U2-10                                   | RMH BOTTEM FOR WEIGH FEEDERS-3 NOS.)       | BAG FILTER               |
| U2-11                                   | BLENDING SILO TOP – SILO VENT              | BAG FILTER               |
| U2-12                                   | BLENDING SILO TOP – (DB+BE/VP/PUMP)        | BAG FILTER               |
| U2-13                                   | SILO DISCH. BIN (KILN FEED BIN)            | BAG FILTER               |
| U2-14                                   | PREHEATER TOP (BE/VP/PUMP VENT)            | BAG FILTER               |
| U2-15                                   | COOLER DISCHARGE ABOVE DBC                 | BAG FILTER               |
| U2-16                                   | CSP TOP                                    | BAG FILTER               |
| U2-17                                   | CSP EXTRACTION – 2 NOS.                    | BAG FILTER               |
| U2-18                                   | TP-9 (@CSP OUTLET)                         | BAG FILTER               |
| U2-19                                   | TP-10 (@CMH. FEEDING CONV.)                | BAG FILTER               |
| U2-20                                   | CEMENT MILL HOPPERS TOP                    | BAG FILTER               |
| U2-21                                   | CEMENT MILL HOPPERS BOTTEM (WEIGH FEEDERS) | BAG FILTER               |
| U2-22                                   | CEMENT SILO TOP (SILO VENT)                | BAG FILTER               |
| U2-23                                   | CEMENT SILO TOP (BE/VP PUMP+DB)            | BAG FILTER               |
| U2-24                                   | PACKING PLANT (PACKER #2)                  | BAG FILTER               |
| U2-25                                   | TP-II(@COAL TRANSFER POINT)                | BAG FILTER               |
| U2-26                                   | RAW COAL HOPPERS TOP                       | BAG FILTER               |
| U2-27                                   | COAL MILL BUILDING – 3 NOS.                | BAG FILTER               |
| U2-28                                   | @TP -4 (BC-1 SPLITTING)                    | BAG FILTER               |
| U2-29                                   | @TP-5 (LSP-II EXTRACTION)                  | BAG FILTER               |
| U2-30                                   | @TP-6 (STACKER FEEDING TP)                 | BAG FILTER               |
| U2-31                                   | @TP-7 (RECLAIMER DISCHARGE. TP)            | BAG FILTER               |
| U2-32                                   | ADDITIVE DUMP HOPPER                       | BAG FILTER               |
| U2-33                                   | ADDITIVE DUMP CRUSHER                      | BAG FILTER               |
| U2-34                                   | @CMB-I (SEPERATOR CHIMNEY – TAPPING)       | BAG FILTER               |
| U2-35                                   | FLY-ASH SILO TOP                           | BAG FILTER               |
| U2-36                                   | CEMENT SILO #3 TOP (SILO VENT)             | BAG FILTER               |
| U2-37                                   | CEMENT SILO #3 TOP (BE/VP/PUMP VENT)       | BAG FILTER               |
| U2-38                                   | PACKING PLANT (PACKER #3)                  | BAG FILTER               |
| U2-39                                   | EXTENDED TUNNEL CLINKER FEED POINT         | BAG FILTER               |

The emission from Cooler, Kiln, cement mill is passed through ESP which reduces the particulate matter to the minimum levels. The emission from Coal Mill, Kiln and Cement Mill are passed through Bag filters.

### 7.2.2 Ambient Air Quality

Ambient air quality monitoring is carried out regularly at mines to know the status of the ambient air quality.

Ambient air quality is monitored for 24 hours at each station for the estimation of PM<sub>10</sub>, PM<sub>2.5</sub>, SO<sub>2</sub>, NO<sub>x</sub>. Estimated average values for the parameters monitored are represented in the Table 7.2 the analyzed values for PM<sub>10</sub>, PM<sub>2.5</sub>, SO<sub>2</sub> and NO<sub>x</sub> are within limits prescribed by A.P.P.C.B.

**Table 7.2**

#### **AVERAGE VALUES OF AMBIENT AIR QUALITY DATA**

| Location              | Parameters       |                   |                 |                 |
|-----------------------|------------------|-------------------|-----------------|-----------------|
|                       | PM <sub>10</sub> | PM <sub>2.5</sub> | SO <sub>2</sub> | NO <sub>x</sub> |
| Near Security gate    | 70.38            | 28.39             | 16.07           | 21.36           |
| Near Cement mill area | 72.33            | 54.4              | 16.90           | 21.85           |
| Near Crushing area    | 70.60            | 29.37             | 15.45           | 21.29           |
| Colony                | 65.60            | 26.71             | 15.35           | 19.58           |

Note: All the values are expressed as ( $\mu\text{g}/\text{m}^3$ )

### **7.2.3 Noise Pollution**

Noise Levels are measured at various places in the factory premises by using a sound level meter. The noise levels were found to be within the limits prescribed by APPCB. The management provided ear muffs for workers who are exposing to high noise levels. The industry has provided industrial type silencers for Diesel Generator sets for controlling noise pollution.

**Table  
Ambient Noise Levels**

| <b>S.No.</b> | <b>Location</b>  | <b>Noise Levels in<br/>dB(A)</b> | <b>Noise Levels in<br/>dB(A)</b> |
|--------------|------------------|----------------------------------|----------------------------------|
|              |                  | <b>Day Time</b>                  | <b>Night Time</b>                |
| 1            | Near Raw Mill    | 71.94                            | 68.84                            |
| 2            | Near QC Lab      | 67.69                            | 63.32                            |
| 3            | Near Time Office | 69.71                            | 65.05                            |
| 4            | Near Colony      | 63.60                            | 53.25                            |

## 8. GREENBELT DEVELOPMENT

| <b>DETAILS OF SPECIES FOR GREEN BELT DEVELOPMENT FOR THE YEAR<br/>2018-2019</b> |              |
|---|--------------|
| <b>PLANT AREA</b>   |              |
| AREA IN ACRES   |              |
| NO. OF PLANTS   | 1150 Plants  |
| NAME OF THE SPECIES   | Dubai        |
| Survival rate (%)   | 85%          |
| WATER SUPPLY  | Water Tanker |
|   |              |
|   |              |
|   |              |
|   |              |
|   |              |
| AREA IN ACRES   |              |
| NO. OF PLANTS   | 1150         |
| GRAND TOTAL   | 1150         |

Note: 1150 Plants are planted in between the total area. (Which were not survived plants.)

## **9. HOUSEKEEPING:**

Proper cleaning of the different sections is required to maintain healthy environment, to avoid unnecessary loss of product in the form of dust emission and polluting surrounding environment. Water spraying is done inside the factory premises to control fugitive emissions from coal yard and raw material storage yards. Stores to be maintain properly. Factory premises are to be clean and green to have good housekeeping. **M/s. PARASAKTI CEMENT INDUSTRIES LTD**, is keeping their plant and premises neat tidy. Housekeeping has been found to be well.

**ANNEXURE-1**

**MONTH WISE WATER CONSUMPTION FOR THE YEAR 2018-19**

| <b>MONTH</b> | <b>INDUSTRIAL(KL)</b> | <b>DOMESTIC(KL)</b> | <b>TOTAL(KL)</b> |
|--------------|-----------------------|---------------------|------------------|
| APR'18       | 4559                  | 2490                | 7049             |
| MAY'18       | 4782                  | 3040                | 7822             |
| JUN'18       | 3531                  | 2740                | 6271             |
| JUL'18       | 3911                  | 2710                | 6621             |
| AUG'18       | 3926                  | 2420                | 6346             |
| SEP'18       | 3348                  | 2730                | 6078             |
| OCT'18       | 3326                  | 3330                | 6656             |
| NOV'18       | 3145                  | 3190                | 6335             |
| DEC'18       | 2360                  | 3260                | 5620             |
| JAN'19       | 926                   | 3110                | 4036             |
| FEB'19       | 1382                  | 2520                | 3902             |
| MAR'19       | 2157                  | 2800                | 4957             |
| <b>TOTAL</b> | <b>37353</b>          | <b>34340</b>        | <b>71693</b>     |

## ANNEXURE - 2

| LINE-1 RAW MATERIAL CON-2018-2019 |                 |                |              |             |                 |              |               |              |             |
|-----------------------------------|-----------------|----------------|--------------|-------------|-----------------|--------------|---------------|--------------|-------------|
| MONTH                             | Limestone Cons. | Dolomite Cons. | Laterite     | Iron Ore    | Gypsum          | Fly Ash      | Slag          | Coal Imp     | Pvt Coal    |
| APR'18                            | 63619           | 673            | 1782         | 1255        | 1186            | 8190         | 0.00          | 6585         | 231         |
| MAY'18                            | 8207            | 87             | 262          | 157         | 1038            | 7972         | 0.00          | 789          | 49          |
| JUN'18                            | 0               | 0              | 0            | 0           | 809             | 7198         | 0.00          | 0            | 0           |
| JUL'18                            | 21516           | 229            | 775          | 370         | 953             | 7638         | 0.00          | 2199         | 125         |
| AUG'18                            | 22792           | 243            | 789          | 375         | 1253            | 9523         | 0.00          | 2005         | 473         |
| SEP'18                            | 19450           | 209            | 792          | 375         | 1028            | 9051         | 0.00          | 1413         | 619         |
| OCT'18                            | 23761           | 382            | 916          | 382         | 1250            | 9697         | 0.00          | 1626         | 1125        |
| NOV'18                            | 18907           | 243            | 745          | 342         | 1152            | 8812         | 0.00          | 1693         | 245         |
| DEC'18                            | 58714           | 756            | 2400         | 1096        | 1163            | 8398         | 0.00          | 7272         | 0.00        |
| JAN'19                            | 13964           | 179            | 587          | 224         | 1112            | 7650         | 0.00          | 1394         | 0.00        |
| FEB'19                            | 18484           | 238            | 484          | 537         | 1392            | 6460         | 0.00          | 1980         | 0.00        |
| MAR'19                            | 64008           | 821            | 2237         | 1448        | 1556.01         | 8228         | 706.01        | 6283         | 0.00        |
| <b>TOTAL</b>                      | <b>333422</b>   | <b>4060</b>    | <b>11769</b> | <b>6561</b> | <b>13892.01</b> | <b>98817</b> | <b>706.01</b> | <b>33239</b> | <b>2867</b> |

## ANNEXURE - 2

| <b>LINE-2 RAW MATERIAL CON-2018-2019</b> |                 |                |              |              |                 |             |                |                  |                 |
|--|-----------------|----------------|--------------|--------------|-----------------|-------------|----------------|------------------|-----------------|
| <b>MONTH</b>                             | Limestone Cons. | Dolomite Cons. | Laterite     | Iron Ore     | Gypsum          | Fly Ash     | Slag           | Coal Imp         | <b>Pvt Coal</b> |
| APR'18                                   | 12096           | 128            | 360          | 244.         | 1856            | 0.00        | 0.00           | 988              | 85              |
| MAY'18                                   | 114812          | 1228           | 4675         | 2066         | 1744            | 0.00        | 0.00           | 10207            | 1633            |
| JUN'18                                   | 92354           | 988            | 3712         | 1777         | 2314            | 0.00        | 0.00           | 7850             | 962             |
| JUL'18                                   | 85894           | 916            | 2960         | 1682         | 2188            | 0.00        | 0.00           | 7523             | 780             |
| AUG'18                                   | 94534           | 1008           | 3640         | 1804         | 2399            | 0.00        | 0.00           | 8709             | 911             |
| SEP'18                                   | 80701           | 864            | 3285         | 1557         | 2501            | 0.00        | 169.82         | 6637             | 1436            |
| OCT'18                                   | 101088          | 1521           | 3890         | 1571         | 2374            | 0.00        | 0.00           | 9218             | 2089            |
| NOV'18                                   | 103827          | 1337           | 4063         | 2197         | 2658            | 0.00        | 0.00           | 10148.16         | 901.84          |
| DEC'18                                   | 105757          | 1367           | 4542         | 2362         | 2776            | 0.00        | 0.00           | 12993            | 0.00            |
| JAN'19                                   | 120705          | 1558           | 5205         | 2604         | 2735            | 70          | 0.00           | 14001.           | 0.00            |
| FEB'19                                   | 76029           | 981            | 3198         | 1563         | 2352            | 267         | 0.00           | 8279             | 0.00            |
| MAR'19                                   | 126591          | 1632           | 5167         | 2552         | 3272.28         | 243         | 1114.00        | 13881            | 0.00            |
| <b>TOTAL</b>                             | <b>1114388</b>  | <b>13528</b>   | <b>44697</b> | <b>21979</b> | <b>29169.28</b> | <b>580</b>  | <b>1283.82</b> | <b>110434.16</b> | <b>8797.84</b>  |
| <b>GRAND TOTAL</b>                       | <b>1447810</b>  | <b>17588</b>   | <b>56466</b> | <b>28540</b> | <b>43475.29</b> | <b>9939</b> | <b>1989.83</b> | <b>143673.16</b> | <b>11664.8</b>  |

| <b>CLINKER PRODUCTION, CONSUMPTION &amp; SALES FOR THE YEAR 2018-19</b> |                |                   |             |
|---|----------------|-------------------|-------------|
| <b>UNIT-I</b>   |                |                   |             |
| MONTH   | Production     | Consumption       | Sales       |
| APR'18  | 45718          | 46165             | 0           |
| MAY'18  | 5488           | 3838              | 0           |
| JUN'18  | 0              | 0                 | 0           |
| JUL'18  | 15707          | 13849             | 0           |
| AUG'18  | 15804          | 17817             | 0           |
| SEP'18  | 13084          | 18337.18          | 0           |
| OCT'18  | 16638          | 17151             | 0           |
| NOV'18  | 12353          | 15239             | 0           |
| DEC'18  | 46022          | 22709             | 0           |
| JAN'19  | 8830           | 20595             | 0           |
| FEB'19  | 12770          | 15246             | 0           |
| MAR'19  | 41558          | 33008.99          | 0           |
| <b>Total</b>  | <b>233972</b>  | <b>223955.17</b>  | <b>0.00</b> |
| <b>UNIT-II</b>  |                |                   |             |
| LINE II   | Production     | Consumption       | Sales       |
| APR'18  | 7968           | 31971             | 0           |
| MAY'18  | 83513          | 62385             | 0           |
| JUN'18  | 65773          | 74150             | 0           |
| JUL'18  | 60713          | 61340             | 0           |
| AUG'18  | 68730          | 67716             | 0           |
| SEP'18  | 56933          | 64262             | 0           |
| OCT'18  | 73215          | 67472             | 0           |
| NOV'18  | 71527          | 75160             | 0           |
| DEC'18  | 81050          | 71392             | 0           |
| JAN'19  | 86286          | 69473             | 0           |
| FEB'19  | 53451          | 69077             | 0           |
| MAR'19  | 87582          | 68014.72          | 0           |
| <b>Total</b>  | <b>796741</b>  | <b>782412.72</b>  | <b>0</b>    |
| <b>GRAND TOTAL</b>  | <b>1030713</b> | <b>1006367.89</b> | <b>0.00</b> |

| <b>CEMENT PRODUCTION AND DESPATCH DETAILS 2018-19</b> |        |        |        |       |           |  |          |          |           |          |           |
|---|--------|--------|--------|-------|-----------|--|----------|----------|-----------|----------|-----------|
| <b>UNIT-I</b>   |        |        |        |       |           |  |          |          |           |          |           |
|   | OPC 43 | OPC 53 | PPC    | SRPC  | TOTAL     |  | OPC 43   | OPC 53   | PPC       | SRPC     | TOTAL     |
| MONTH   | PROD   | PROD   | PROD   | PROD  | PROD      |  | DESPATCH | DESPATCH | DESPATCH  | DESPATCH | DESPATCH  |
| APR'18  | 9277   | 0.00   | 23409  | 2121  | 34807.00  |  | 8231.75  | 0.00     | 23791.04  | 1552.00  | 33574.79  |
| MAY'18  | 5034   | 0.00   | 22789  | 878   | 28701.00  |  | 6297.71  | 0.00     | 21908.55  | 1182.02  | 29388.28  |
| JUN'18  | 0      | 0.00   | 20593  | 1293  | 21886.00  |  | 0.00     | 0.00     | 22049.73  | 1251.98  | 23301.71  |
| JUL'18  | 365    | 2557   | 22815  | 0     | 25737.00  |  | 365.00   | 2557.00  | 22462.93  | 827.31   | 26212.24  |
| AUG'18  | 1720   | 2222   | 29325  | 572   | 33839.00  |  | 1720.00  | 2222.00  | 28451.60  | 233.67   | 32627.27  |
| SEP'18  | 1084   | 0      | 25919  | 777   | 27780.00  |  | 1084.00  | 0.00     | 26036.75  | 342.28   | 27463.03  |
| OCT'18  | 2017   | 2765   | 27844  | 1180  | 33806.00  |  | 2017.00  | 2765.00  | 28382.50  | 951.94   | 34116.44  |
| NOV'18  | 3227   | 489    | 27056  | 381   | 31153.00  |  | 3227.00  | 489.00   | 26155.25  | 711.50   | 30582.75  |
| DEC'18  | 5429   | 0.00   | 25135  | 839   | 31403.00  |  | 4159.00  | 0.00     | 24803.90  | 660.60   | 29623.50  |
| JAN'19  | 4307   | 0.00   | 24382  | 668   | 29357.00  |  | 5006.85  | 0.00     | 25865.40  | 1009.50  | 31881.75  |
| FEB'19  | 4753   | 6549   | 22570  | 2039. | 35911.00  |  | 5323.25  | 6549.00  | 22753.34  | 1354.27  | 35979.86  |
| MAR'19  | 7490   | 3059   | 31912  | 1452  | 43913.00  |  | 7059.11  | 3059.00  | 31062.63  | 1577.00  | 42757.74  |
| TOTAL   | 44703  | 17641  | 303749 | 12200 | 378293.00 |  | 44490.67 | 17641.00 | 303723.62 | 11654.07 | 377509.36 |

| <b>UNIT-II</b>     |              |               |               |              |                |  |                 |                  |                  |                 |                   |
|--------------------|--------------|---------------|---------------|--------------|----------------|--|-----------------|------------------|------------------|-----------------|-------------------|
|                    | OPC 43       | OPC 53        | PPC           | SRPC         | TOTAL          |  | OPC 43          | OPC 53           | PPC              | SRPC            | TOTAL             |
| MONTH              | PROD         | PROD          | PROD          | PROD         | PROD           |  | DESPATCH        | DESPATCH         | DESPATCH         | DESPATCH        | DESPATCH          |
| APR'18             | 0            | 54561         | 0             | 0.00         | 54561          |  | 0.00            | 52808.11         | 0.00             | 0.00            | 52808.11          |
| MAY'18             | 1096         | 47180         | 0             | 0.00         | 48276          |  | 778.39          | 49847.92         | 0.00             | 0.00            | 50626.31          |
| JUN'18             | 5806         | 56779         | 0.00          | 0.00         | 62585          |  | 5415.03         | 56399.68         | 0.00             | 0.00            | 61814.71          |
| JUL'18             | 4268         | 55021         | 0.00          | 942.00       | 60231          |  | 4766.16         | 54262.31         | 0.00             | 0.00            | 59028.47          |
| AUG'18             | 5257         | 59612         | 0.00          | 0.00         | 64869          |  | 4499.87         | 60616.14         | 0.00             | 593.78          | 65709.79          |
| SEP'18             | 4107         | 63462         | 0.00          | 0.00         | 67569          |  | 3848.44         | 61543.41         | 0.00             | 348.22          | 65740.07          |
| OCT'18             | 3704         | 60434         | 0.00          | 0.00         | 64138          |  | 4105.17         | 61996.36         | 0.00             | 0.00            | 66101.53          |
| NOV'18             | 3620         | 68248         | 0.00          | 0.00         | 71868          |  | 3912.13         | 65972.03         | 0.00             | 0.00            | 69884.16          |
| DEC'18             | 1809         | 73226         | 0.00          | 0.00         | 75035          |  | 2311.91         | 71771.86         | 0.00             | 0.00            | 74083.77          |
| JAN'19             | 2624         | 69454         | 200.00        | 0.00         | 72278          |  | 2622.34         | 77490.00         | 200.00           | 0.00            | 80312.34          |
| FEB'19             | 1506         | 56031         | 1307.00       | 0.00         | 58844          |  | 1289.86         | 56671.01         | 1307.00          | 0.00            | 59267.87          |
| MAR'19             | 1963         | 69623         | 1058.00       | 0.00         | 72644          |  | 2210.7          | 67220.38         | 1058.00          | 0.00            | 70489.08          |
| TOTAL              | 35760        | 733631        | 2565          | 942          | 772898         |  | 35760.00        | 736599.21        | 2565.00          | 942.00          | 775866.21         |
| <b>GRAND TOTAL</b> | <b>80463</b> | <b>751272</b> | <b>306314</b> | <b>13142</b> | <b>1151191</b> |  | <b>80250.67</b> | <b>754240.21</b> | <b>306288.62</b> | <b>12596.07</b> | <b>1153375.57</b> |

**EXPENDITURE ON POLLUTION CONTROL EQUIPMENT & MONITORING 2018-2019**

|   | CRUSHER        | KILN ESP         | CEMENT MILL     | RAWMILL          | KILN              | COALMILL        | CEMENT MILL      | PACKING         | TOTAL             |
|---|----------------|------------------|-----------------|------------------|-------------------|-----------------|------------------|-----------------|-------------------|
| LINE-1                                      | 482.97         | 319982.95        |                 | 259.08           | 13439.31          | 2220.45         | 46956.31         | 52860.24        | 436201.31         |
| LINE-2                                      |                | 69855.29         | 72966.84        | 131863.39        | 5198146.11        | 31874.79        | 165018.71        |                 | 5669725.13        |
| <b>TOTAL</b>                                | <b>482.97</b>  | <b>389838.24</b> | <b>72966.84</b> | <b>132122.47</b> | <b>5211585.42</b> | <b>34095.24</b> | <b>211975.02</b> | <b>52860.24</b> | <b>6105926.44</b> |
| <b>LINE 1 &amp; 2</b>                       |                |                  |                 |                  |                   |                 |                  |                 |                   |
| STP MAINTENANCE                             |                |                  |                 |                  |                   |                 |                  |                 | <b>566400.00</b>  |
| P&A WELFARE-STP                             |                |                  |                 |                  |                   |                 |                  |                 | <b>56686 .84</b>  |
| P&A WELFARE -DRINKING WATER TREATMENT PLANT |                |                  |                 |                  |                   |                 |                  |                 | <b>64037.25</b>   |
| ROAD SWEEPING MACHINE                       |                |                  |                 |                  |                   |                 |                  |                 | <b>394315.04</b>  |
| VACCUME CLEANER                             |                |                  |                 |                  |                   |                 |                  |                 | <b>180938.98</b>  |
| MONTHLY MONITORING CHARGES                  |                |                  |                 |                  |                   |                 |                  |                 | <b>252960.00</b>  |
| POLLUTION MONITORING EQUIPMENTS             |                |                  |                 |                  |                   |                 |                  |                 | <b>1593358.82</b> |
| APPCB WATER CESS & ANALYSIS CHARGES         |                |                  |                 |                  |                   |                 |                  |                 | <b>69831.00</b>   |
| HORTICULTURE                                |                |                  |                 |                  |                   |                 |                  |                 | <b>160655.81</b>  |
| PLANTATION                                  |                |                  |                 |                  |                   |                 |                  |                 | <b>1967360</b>    |
| TOTAL PLANTATION & HORTICULTURE             |                |                  |                 |                  |                   |                 |                  |                 | <b>2128016</b>    |
| POWER CONSUMPTION ON POLLUTION EQUIP        |                |                  |                 |                  |                   |                 |                  |                 | <b>38154247</b>   |
| <b>Grand TOTAL</b>                          |                |                  |                 |                  |                   |                 |                  |                 | <b>49566717</b>   |
| HAZARDOUS WASTE (OIL) KL                    | <b>1.05KL</b>  |                  |                 |                  |                   |                 |                  |                 |                   |
| (GREASE)Tons                                | <b>7.098MT</b> |                  |                 |                  |                   |                 |                  |                 |                   |
| Batteries scrap- used batteries. Tons       | <b>1.034MT</b> |                  |                 |                  |                   |                 |                  |                 |                   |
| Used Grinding Media. Tons                   | <b>NIL</b>     |                  |                 |                  |                   |                 |                  |                 |                   |

| <b>MONTHLY WISE CONSUMPTION OF ELECTRICAL ENERGY FROM APSPDCL / GENERATION OF ELECTRICAL ENERGY FROM D.G.SETS/DIESEL CONSUMPTION FOR THE YEAR OF 2018-2019.</b> |   |  |                        |
|---|---|--|------------------------|
| <b>MONTH</b>  | <b>ELECTRICAL ENERGY FROM APSPDCL (KWH)</b> | <b>ELECTRICAL ENERGY FROM D.G. SET (KWH/Hr.)</b> | <b>WHR UNITS (KWH)</b> |
| APR'18  | 7357620                                     | 0  | 0                      |
| MAY'18  | 7681440                                     | 0  | 0                      |
| JUN'18  | 7849560                                     | 0  | 0                      |
| JUL'18  | 6391800                                     | 0  | 0                      |
| AUG'18  | 8511180                                     | 0  | 0                      |
| SEP'18  | 8691180                                     | 0  | 43800                  |
| OCT'18  | 6936540                                     | 0  | 1229452                |
| NOV'18  | 7999320                                     | 0  | 2169877                |
| DEC'18  | 6998400                                     | 0  | 3765360                |
| JAN'19  | 6842460                                     | 0  | 4257523                |
| FEB'19  | 5214060                                     | 0  | 2011850                |
| MAR'19  | 7379100                                     | 0  | 4739650                |
| <b>TOTAL</b>  | <b>87852660</b>                             | <b>0</b>   | <b>18217512</b>        |